

SJ7127/35 RT ROUGH TERRAIN SCISSORS

Dimensions	SJ7127 RT	SJ7135 RT
A Work Height	33' (10.06 m)	41' (12.50 m)
B Raised Platform Height	27' (8.23 m)	35' (10.67 m)
C Lowered Platform Height	60.5" (1.54 m)	67.5" (1.71 m)
D Overall Width	71" (1.80 m)	71" (1.80 m)
E Overall Length	127" (3.23 m)	127" (3.23 m)
F Stowed Height (Rails Up)	105.5" (2.68 m)	112.5" (2.86 m)
G Stowed Height (Rails Down)	77" (1.96 m)	84" (2.13 m)
H Platform Width (Inside Dimension)	64" (1.63 m)	64" (1.63 m)
I Platform Length (Inside Dimension)	116.5" (2.96 m)	116.5" (2.96 m)
Specifications	SJ7127 RT	SJ7135 RT
Extension Deck	4.5' (1.37 m)	4.5' (1.37 m)
Ground Clearance	8.5" (0.22 m)	8.5" (0.22 m)
Wheelbase	95" (2.41 m)	95" (2.41 m)
Weight	8,420 lbs (3,819 kg)	8,850 lbs (4,014 kg)
Gradeability	30%	30%
Turning Radius (Inside)	109" (2.77 m)	109" (2.77 m)
Turning Radius (Outside)	207" (5.26 m)	207" (5.26 m)
Lift Time (With Rated Load)	43 sec	41 sec
Lower time (With Rated Load)	46 sec	44 sec
Drive Speed (Stowed)	3 mph (4.8 km/h)	3 mph (4.8 km/h)
Drive Speed (Raised)	0.35 mph (0.6 km/h)	0.35 mph (0.6 km/h)
Maximum Drive Height	Full Height	Full Height
Capacity (Overall)	1,500 lbs (680 kg)	1,000 lbs (454 kg)
Distributed Capacity (Main Platform)	1,000 lbs (454 kg)	650 lbs (295 kg)
Distributed Capacity (Extension Deck)	500 lbs (227 kg)	350 lbs (159 kg)
Local Floor Load (With Rated Load)	121 psi (835 kPa)	120 psi (835 kPa)
Overall Floor Load (With Rated Load)	228 psf (11 kPa)	227 psf (11 kPa)
Maximum # of Persons	5	4
Tire Type	Air Filled	Air Filled
Tire Size	10 x 16.5	10 x 16.5

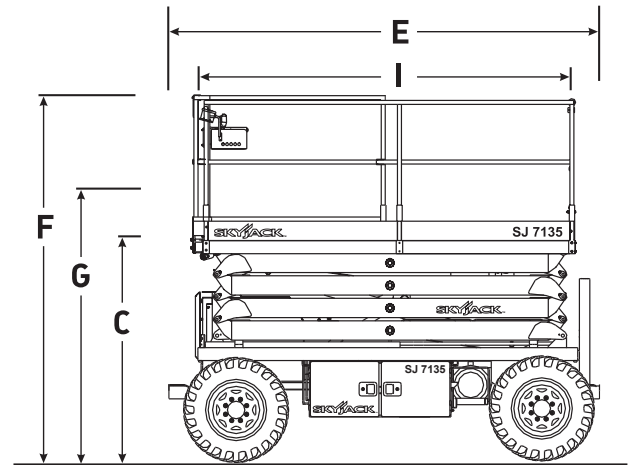
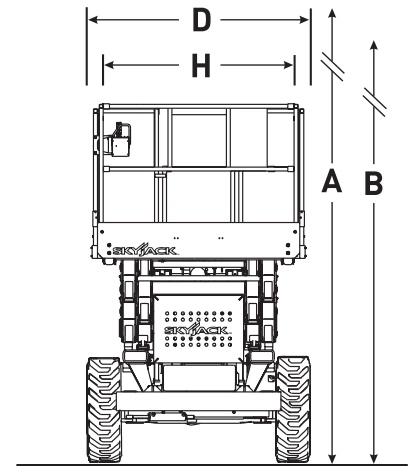

Skyjack Head Office
 55 Campbell Rd. Guelph, ON Canada N1H 1B9
 Sales Inquiries: 1-877-755-4387 (1-877-SJLIFTS)
 Main Switchboard: 1-800-265-2738
 Phone: 519-837-0888
 Fax: 519-837-8104
 Email: skyjack@skyjack.com
 www.skyjack.com

This brochure is for illustrative purpose only and based on the latest information at the time of printing. Skyjack Inc. reserves the right to make changes at any time, without notice, to specifications, standard and optional equipment. Consult the Operating Maintenance and Parts Manuals for proper procedures. Work platforms have been tested to comply with ANSI and CSA standards as interpreted by Skyjack Inc.

