

SJIII 3220/26 ELECTRIC SCISSOR LIFTS

Dimensions	SJIII 3220	SJIII 3226
A Work Height	26' (7.92 m)	32' (9.75 m)
B Raised Platform Height	20' (6.10 m)	26' (7.92 m)
C Lowered Platform Height	38" (0.97 m)	45" (1.14 m)
D Overall Width	32" (0.81 m)	32" (0.81 m)
E Overall Length	91.5" (2.32 m)	91.5" (2.32 m)
F Stowed Height (Rails Up)	77.5" (1.97 m)	84.7" (2.15 m)
G Stowed Height (Rails Down)	OPT 63.5" (1.61 m)	70.6" (1.79 m)
H Platform Width (Inside Dimension)	28" (0.71 m)	28" (0.71 m)
I Platform Length (Inside Dimension)	84" (2.13 m)	84" (2.13 m)
Specifications	SJIII 3220	SJIII 3226
Extension Deck (Roll Out)	3' (0.91 m)	3' (0.91 m)
Ground Clearance (Stowed)	3.5" (8.89 cm)	3.5" (8.89 cm)
Ground Clearance (Raised)	0.75" (1.90 cm)	0.75" (1.90 cm)
Wheelbase	69" (1.75 m)	69" (1.75 m)
Weight	3,510 lbs (1,592 kg)	4,135 lbs (1,876 kg)
Gradeability	30%	30%
Turning Radius (Inside)	50" (1.27 m)	50" (1.27 m)
Turning Radius (Outside)	108" (2.74 m)	108" (2.74 m)
Lift Time (With Rated Load)	33 sec	56 sec
Lower time (With Rated Load)	29 sec	42 sec
Drive Speed (Stowed)	2 mph (3.2 km/h)	2.4 mph (3.9 km/h)
Drive Speed (Raised)	0.7 mph (1.1 km/h)	0.7 mph (1.1 km/h)
Maximum Drive Height	Full Height	Full Height
Capacity (Overall)	900 lbs (408 kg)	500 lbs (227 kg)
Distributed Capacity (Main Platform)	600 lbs (159 kg)	250 lbs (113 kg)
Distributed Capacity (Extension Deck)	300 lbs (136 kg)	250 lbs (113 kg)
Local Floor Load (With Rated Load)	130 psi (897 kPa)	130 psi (897 kPa)
Overall Floor Load (With Rated Load)	245 psf (12 kPa)	235 psf (12 kPa)
Maximum # of Persons	2	2
Wind Rating	28 mph (12.5 m/s)	28 mph (12.5 m/s)
Tire Type	Solid, N/M	Solid, N/M
Tire Size	16 x 5 x 12	16 x 5 x 12

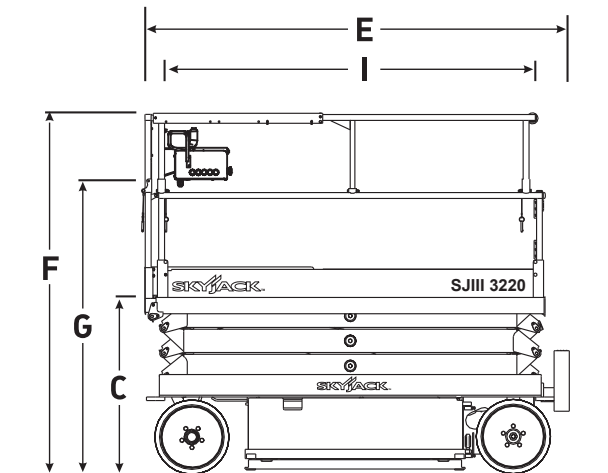
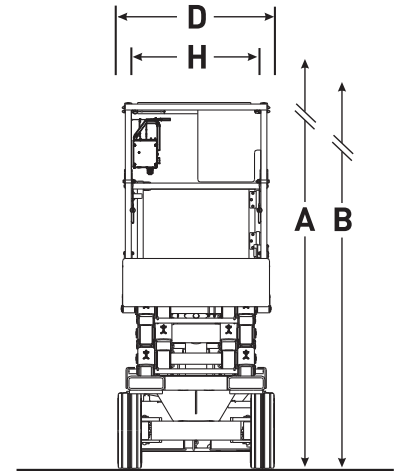

Skyjack Head Office
 55 Campbell Rd. Guelph, ON Canada N1H 1B9
 Sales Inquiries: 1-877-755-4387 (1-877-SJLIFTS)
 Main Switchboard: 1-800-265-2738
 Phone: 519-837-0888
 Fax: 519-837-8104
 Email: skyjack@skyjack.com
 www.skyjack.com

This brochure is for illustrative purpose only and based on the latest information at the time of printing. Skyjack Inc. reserves the right to make changes at any time, without notice, to specifications, standard and optional equipment. Consult the Operating Maintenance and Parts Manuals for proper procedures. Work platforms have been tested to comply with ANSI and CSA standards as interpreted by Skyjack Inc.

