

SJIII 4626/32 ELECTRIC SCISSOR LIFTS

Dimensions	SJIII 4626	SJIII 4632
A Work Height	32' (9.75 m)	38' (11.58 m)
B Raised Platform Height	26' (7.92 m)	32' (9.75 m)
C Lowered Platform Height	45" (1.14 m)	48.5" (1.23 m)
D Overall Width	46" (1.17 m)	46" (1.17 m)
E Overall Length	91" (2.31 m)	91" (2.31 m)
F Stowed Height (Rails Up)	84.5" (2.15 m)	88" (2.24 m)
G Stowed Height (Rails Down)	70.5" (1.79 m)	74" (1.88 m)
H Platform Width (Inside Dimension)	42" (1.07 m)	42" (1.07 m)
I Platform Length (Inside Dimension)	84" (2.13 m)	84" (2.13 m)
Specifications	SJIII 4626	SJIII 4632
Extension Deck (Roll Out)	4' (1.22 m)	4' (1.22 m)
Ground Clearance (Stowed)	3.5" (8.89 cm)	3.5" (8.89 cm)
Ground Clearance (Raised)	0.75" (1.91 cm)	0.75" (1.91 cm)
Wheelbase	69" (1.75 m)	69" (1.75 m)
Weight	4,700 lbs (2,132 kg)	5,075 lbs (2,302 kg)
Gradeability	30%	25%
Turning Radius (Inside)	47.5" (1.21 m)	47.5" (1.21 m)
Turning Radius (Outside)	93.5" (2.37 m)	93.5" (2.37 m)
Lift Time (With Rated Load)	54 sec	59 sec
Lower time (With Rated Load)	32 sec	49 sec
Drive Speed (Stowed)	2 mph (3.2 km/h)	2 mph (3.2 km/h)
Drive Speed (Raised)	0.6 mph (1 km/h)	0.6 mph (1 km/h)
Maximum Drive Height	Full Height	Full Height
Capacity (Overall)	1,000 lbs (454 kg)	700 lbs (318 kg)
Distributed Capacity (Main Platform)	700 lbs (318 kg)	450 lbs (204 kg)
Distributed Capacity (Extension Deck)	300 lbs (136 kg)	250 lbs (113 kg)
Local Floor Load (With Rated Load)	235 psi (1620 kPa)	220 psi (1517 kPa)
Overall Floor Load (With Rated Load)	191 psf (9 kPa)	204 psf (10 kPa)
Maximum # of Persons	3	2
Wind Rating	28 mph (12.5 m/s)	28 mph (12.5 m/s)
Tire Type	Solid, N/M	Solid, N/M
Tire Size	16 x 5 x 12	16 x 5 x 12

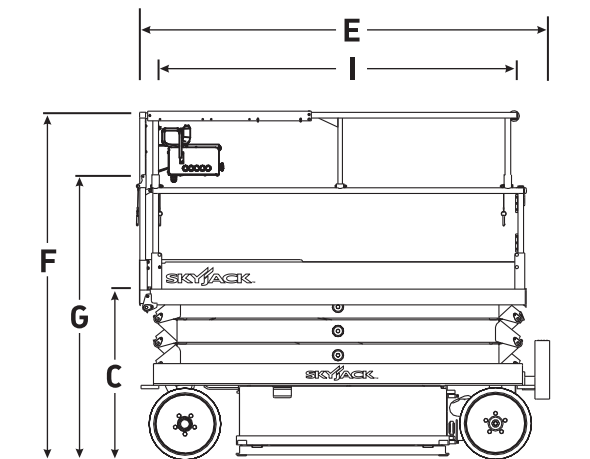
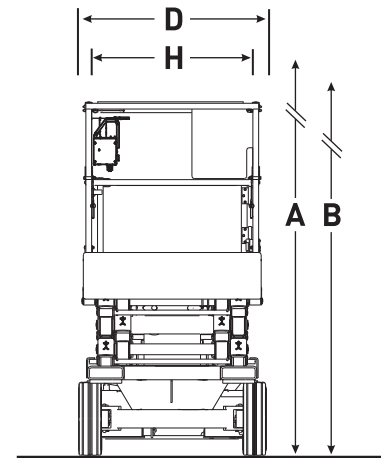

Skyjack Head Office

55 Campbell Rd. Guelph, ON Canada N1H 1B9
 Sales Inquiries: 1-877-755-4387 (1-877-SJLIFTS)
 Main Switchboard: 1-800-265-2738
 Phone: 519-837-0888
 Fax: 519-837-8104
 Email: skyjack@skyjack.com
 www.skyjack.com

This brochure is for illustrative purpose only and based on the latest information at the time of printing. Skyjack Inc. reserves the right to make changes at any time, without notice, to specifications, standard and optional equipment. Consult the Operating Maintenance and Parts Manuals for proper procedures. Work platforms have been tested to comply with ANSI and CSA standards as interpreted by Skyjack Inc.

